

SPRING-LOADED CONNECTORS

SERIES 945 • OMNIBALL™ CIRCULAR SPRING-LOADED CONNECTOR • SURFACE MOUNT

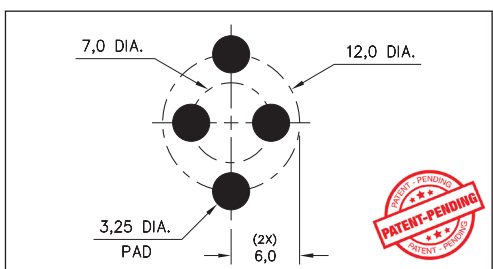
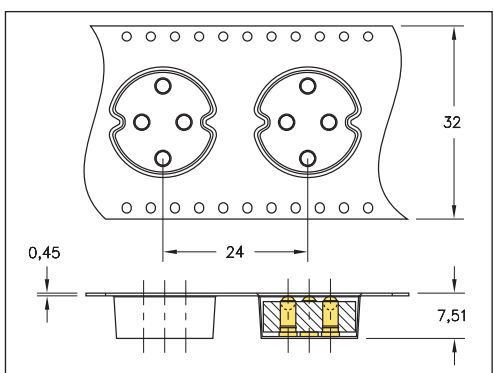
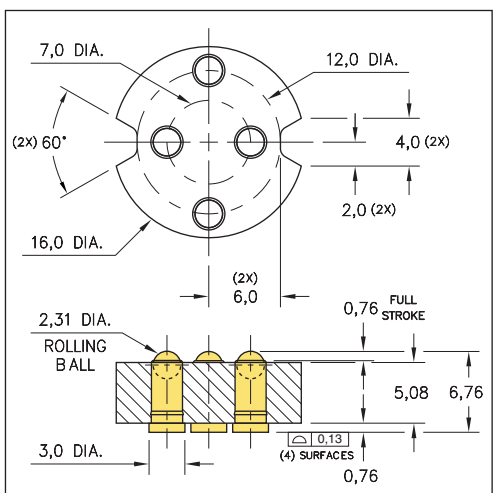
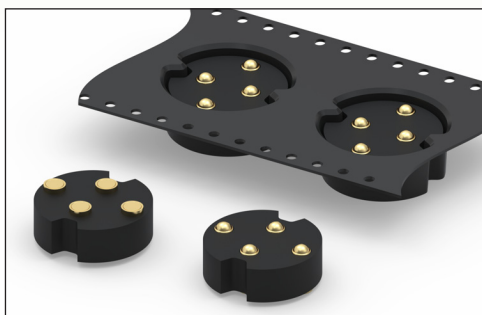

- These connectors utilize the unique Omniball™ spring loaded contact (patent pending), a rolling ball interface which enables mating surfaces to slide into contact with each other in blind mate or “twist & lock” applications. The Omniball™ contact pins are designed to compress and roll, supporting lateral and rotational connections, in either static or dynamic applications, while providing optimal electrical, mechanical and structural reliability
- Precision machined, gold-plated components assure durability of 100,000 – 1,000,000 compression and rolling cycles
- Pistons have a 0,38 mid. stroke and a 0,76 max. stroke
- Low resistance, high current contacts are rated at 3.5 amps continuous, 5 amps peak
- Machined Fr-4 Epoxy insulators are suitable for surface mount soldering processes
- 945 Series surface mount connectors are offered in bulk packaging for manual placement and on tape & reel for automatic pick & place assembly. The recommended pad size is 3,25Ø minimum

ORDERING INFORMATION

Series 945 (Tube Packaged)

945-22-204-30-360101

Series 945 (Tape & Reel Packaged)

945-22-204-30-360191

Technical Specifications for 945 Series

Materials:

Contact ball & base: Machined copper alloy plated 0,51µm gold over 2,54µm nickel
 Spring: Beryllium copper-plated 0,25µm gold
 Insulator: Machined Fr-4 Epoxy, rated UL94 V-0

Mechanical:

Spring force @ initial height: 30 grams
 Spring force @ mid stroke (0,38): 55 grams
 Durability: 100,000 to 1,000,000 cycles

Electrical:

Voltage rating: 100Vrms/150Vdc
 Current rating: 3.5A (continuous), 5A (peak) per contact
 Contact resistance: 20mΩ max.
 Insulation resistance: 10,000MΩ min.
 Dielectric strength: 700Vrms min.
 Capacitance: 1pF max.

RoHS - 2
2011/65/EU