

# MALE PCB PINS

## PRINTED CIRCUIT PINS

### 5920

5920-0-00-XX-00-00-03-0

Solderless press-fit pin for plated through-hole  
Recommended drilled hole size: 2,18mm (.086")

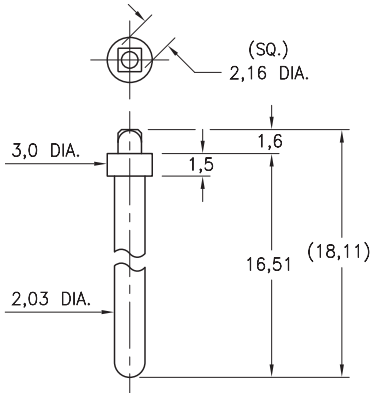

### 6025

6025-0-00-XX-00-00-03-0

Solderless press-fit pin for plated through-hole  
Recommended drilled hole size: 1,73mm (.068")

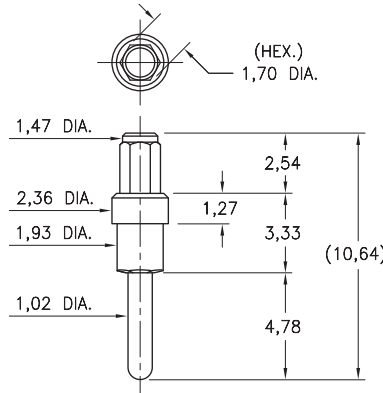

### 6035

6035-0-00-XX-00-00-03-0

Solderless press-fit pin for plated through-hole  
Recommended drilled hole size: 1,73mm (.068")

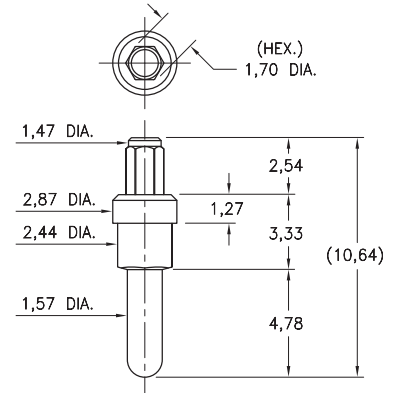

### 8237

8237-0-05-XX-00-00-03-0

Solderless press-fit pin for plated through-hole  
Recommended drilled hole size: 2,34mm (.092")

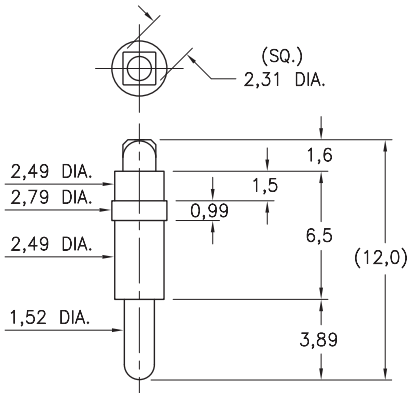

### 6834

6834-0-00-XX-00-00-03-0

Solderless press-fit pin for plated through-hole  
Recommended drilled hole size: 1,3mm (.0512")

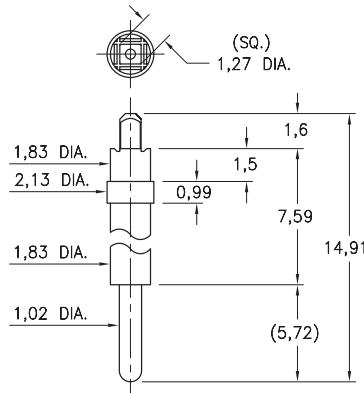

### 6835

6835-0-00-XX-00-00-44-0

Solderless press-fit pin for plated through-hole  
Recommended drilled hole size: 2,34mm (.092")  
\* Pin Material: Tellurium Copper Alloy

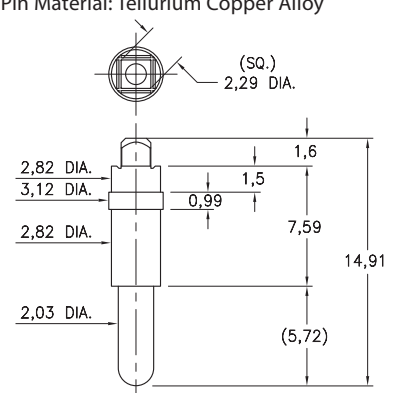

Recommended drilled hole sizes are prior to plating of the PCB and based on typical copper deposition of .5 - 1 oz. This results in a reduction of hole size by approximately 0,038 - 0,076. Depending on surface plating, typical finished hole sizes are 0,076 - 0,127 smaller than drilled hole sizes. The finished hole size tolerance for press-fit applications should be specified as +/- 0,051

#### SPECIFICATIONS:

**Pin Material:** Brass Alloy 360, 1/2 Hard  
(Except where noted) \*

**Dimensions:** Inches

**Tolerances On:** Lengths: ± 0,13  
Diameters: ± 0,051  
Angles: ± 2°



**ORDER CODE:** XXXX - 0 - 0X - XX - 00 - 00 - XX - 0

**BASIC PART #**

**SPECIFY PIN FINISH:**

- 01 5,08µm TIN/LEAD OVER NICKEL
- ◆ 80 5,08µm TIN OVER NICKEL (RoHS)
- ◆ 15 0,25µm GOLD OVER NICKEL (RoHS)
- ◆ 21 0,51µm GOLD OVER NICKEL (RoHS)
- ◆ 34 1,27µm GOLD OVER NICKEL (RoHS)

