

INTERCONNECTS

SERIES 329, 380, 429, 480 • 2,54 GRID SOLDER CUP HEADERS AND SOCKETS • SINGLE AND DOUBLE ROW STRIPS

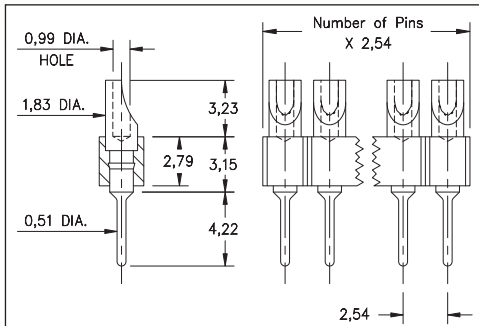

FIG. 1

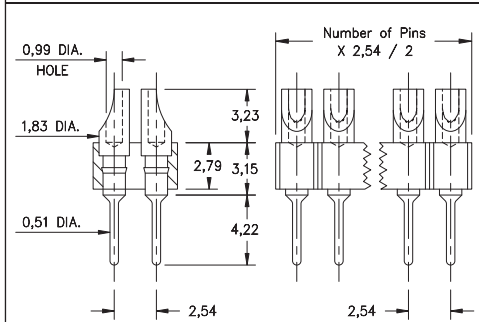

FIG. 2

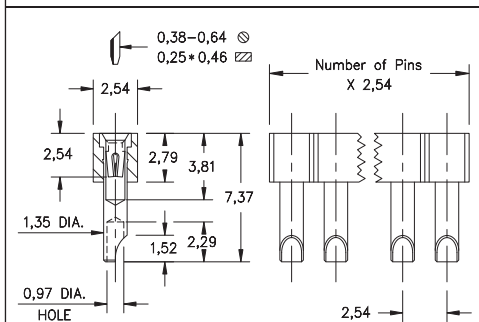

FIG. 3

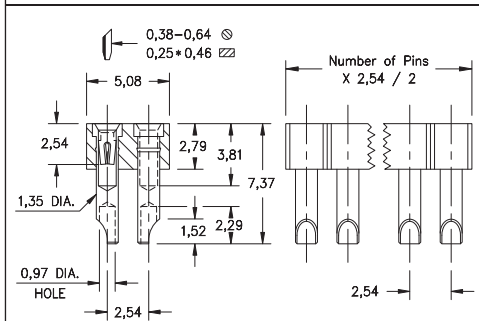
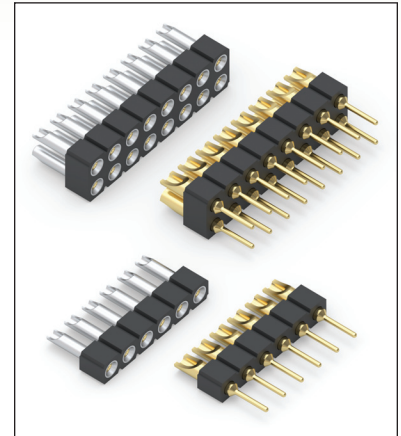

FIG. 4

- Series 380 & 480 use MM #8000 pins. See page 216 for details
- Series 329 & 429 use MM #2954 receptacles and accept pin diameters from 0,38 - 0,64. See page 171 for details
- Series 329 & 429 receptacles use Hi-Rel, 4-finger BeCu #30 contact rated at 3 amps. See page 253 for details
- Soldercups are pre-aligned
- Insulators are high temperature thermoplastic, suitable for all soldering operations



ORDERING INFORMATION

FIG. 1	Series 380...001	Single Row Solder Cup / Solder Tail		
		380-XX-1	-00-001000	01-64
FIG. 2	Series 480...001	Double Row Solder Cup / Solder Tail		
		480-10-2	-00-001000	02-64
XX=Plating Code See Below For Electrical, Mechanical & Environmental Data, See page 264				
SPECIFY PLATING CODE XX=		10	90	40
Pin Plating		0,25µm Au	5,08µm Sn/Pb	5,08µm Sn

FIG. 3	Series 329...540	Single Row Solder Cup Sockets			
		329-XX-1	-41-540000	01-64	
FIG. 4	Series 429...540	Double Row Solder Cup Sockets			
		429-XX-2	-41-540000	02-64	
XX=Plating Code See Below For Electrical, Mechanical & Environmental Data, See page 264					
SPECIFY PLATING CODE XX=		11	13	41	43
Sleeve (Pin)		0,25µm Au	0,25µm Au	5,08µm Sn	5,08µm Sn
Contact (Clip)		0,25µm Au	0,76µm Au	0,25µm Au	0,76µm Au