

REVISIONS						
REV	ECO NO.	DESCRIPTION	BY	DATE	APP'D BY	DATE
1	22529	ORIGINAL RELEASE	TD	5/18/2012		
2	23533	DATAPLATE CHANGE	TD	10/23/2014		

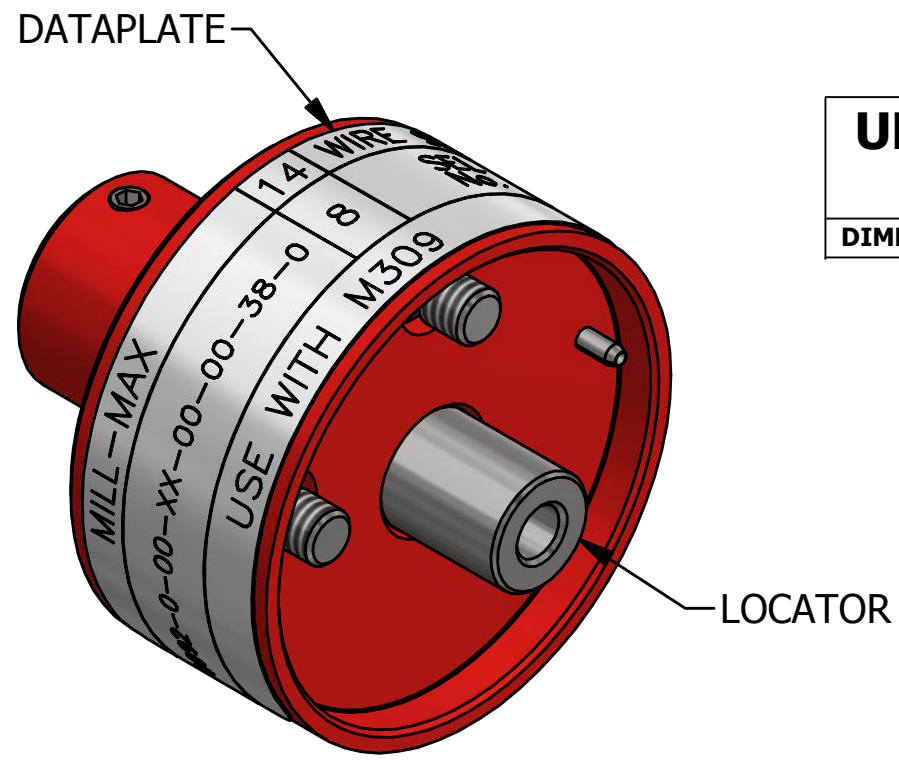
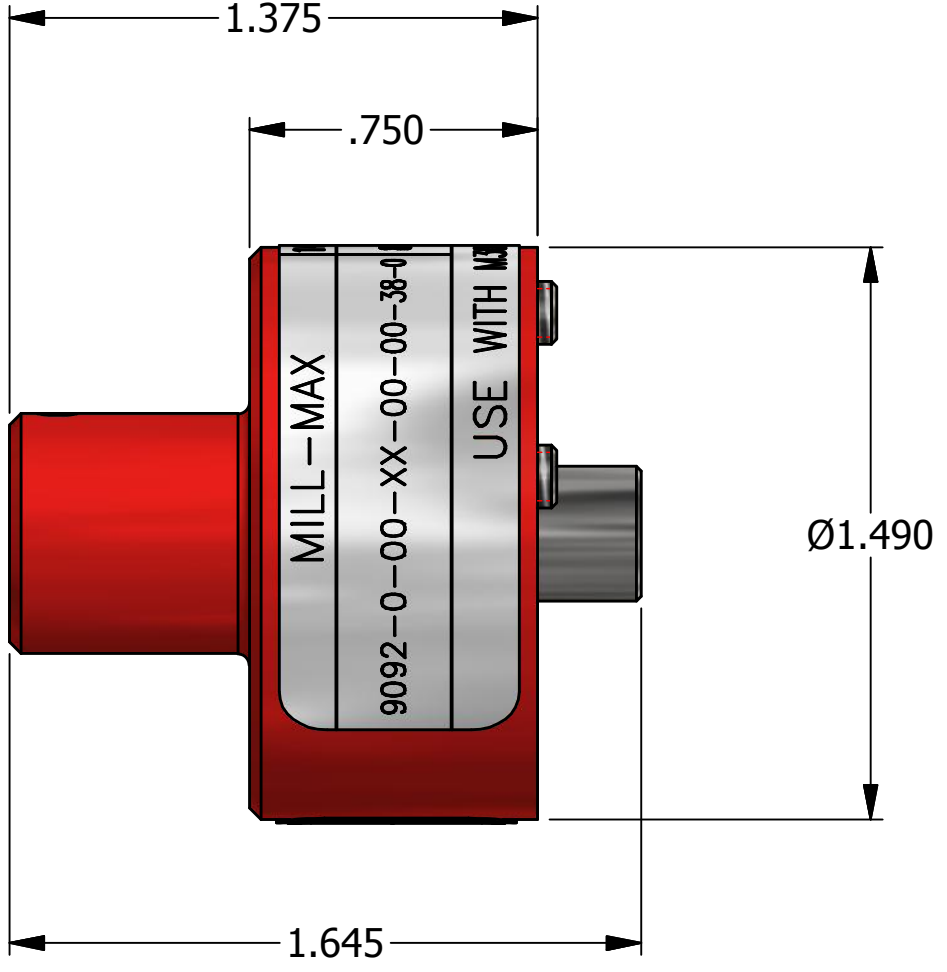

**UNCONTROLLED DOCUMENT  
WILL NOT BE UPDATED**  
DIMENSIONS IN INCHES - UNLESS OTHERWISE SPECIFIED

MILL-MAX	14	WIRE SIZE
9092-0-00-XX-00-00-38-0	8	SEL No.
USE WITH M309		

LOCATOR	
HOLE DIMENSIONS	ADDITIONAL FEATURES
Ø.156 ▽.623	

MATERIAL	ITEM	PART NO.	QTY.	DESCRIPTION / REMARKS
N/A	DRN. Tony Dilworth CHK'D.	DATE 5/11/2012 DATE		<b>DMC</b> DANIELS MANUFACTURING CORP. ORLANDO, FLORIDA CAGE 11851
RESTRICTED & CONFIDENTIAL CONFIDENTIAL PROPERTY OF DANIELS MANUFACTURING CORP. NOT TO BE DISCLOSED TO OTHERS. REPRODUCTION OR USED FOR ANY OTHER PURPOSE EXCEPT AS AUTHORIZED IN WRITING BY DANIELS MANUFACTURING. MUST BE RETURNED TO DANIELS MANUFACTURING CORP. ON COMPLETION OF ORDER OR PURPOSES FOR WHICH LENT.	HEAT TREAT	N/A		NOTE: THIS DRAWING IS AN OUTLINE DRAWING OF THE RESPECTIVE DMC PART NUMBER INDICATED. ACTUAL DMC PART NUMBER IS DRAWING NUMBER WITHOUT THE "-ENV" SUFFIX
CREATED FROM AN INVENTOR MODEL. CHANGES MUST BE REFLECTED IN THE 3D PART	FINISH	N/A		TITLE SINGLE POSITION HEAD ENVELOPE DRAWING WHERE USED: M309
DO NOT SCALE DRAWING				SIZE B SCALE 2:1 CAD P/N TP1698-ENV SHEET 1 OF 1 DWG. NO. TP1698-ENV REV. 2